



Air Curtain

Models

AC10

Standard Features

- Right door hinging
- Perimeter bumper
- 3 wire grounded 8 ft. extension power cord and plug
- Removable tray slides
- Recessed hand grips
- Rear mounted tubular handle
- Two stainless steel flush-in-wall hand grips
- Glass door

Warranty

- Two years parts and one year labor

Options

- Locking door latch
- Padlock transport latch
- Left hand door hinging
- All swivel or larger casters
- Menu card holders
- Door edge trim
- Fixed tray rack assembly
- 6" legs
- Cold plate cartridge
- Cord winding brackets



APPLICATION

The Alluserv Air Curtain refrigerator is designed for tray make-up in healthcare operations. This air curtain is designed to be able to retain its temperature with the door open for up to 90 min. through a 3D air curtain cooling system.

SPECIFICATIONS

Heliarc welded stainless steel cabinet exterior, includes top, back, bottom and one piece louvered grille, are constructed of 18 and 20-gauge stainless steel with #3 finish. Cabinet interior and door liners are constructed of stainless steel with 2-B finish. The unit's insulation consists of high density fiberglass and foam insulation throughout. The two stainless steel hand grips are recess mounted; one on left side and one on right side of unit. One heavy-duty stainless steel tubular handle is mounted in "stand-off" fashion at rear of unit. Flush mounted, stainless steel foam insulated doors are gasket sealed. Each door has three heavy-duty edge mount hinges. Door opens to 270°. The door can be held open by a magnetic device, which comes standard. Maximum air flow design of slides provides a maximum air distribution around product. Slides are designed to give secure bottom tray support and are removable for cleaning. Casters, 2 fixed and 2 swivel with brakes, are 6" in diameter, and 2" rounded with soft tread to ensure a smooth and quiet ride over any surface.

ALLUSERV, LLC

4900 West Electric Avenue | West Milwaukee WI | 53219

888-892-2213 | fax 636-239-8435 | info@alluserv.com | www.alluserv.com

Air Curtain

Models

AC10

Spec #

REFRIGERATION SYSTEM / CONTROLS

Highly accurate digital controls feature continuously intuitive defrost system with on demand override. Unit has heavy-duty fan circulation evaporator coil, 1/2 HP air-cooled closed system. Bottom mounted, self-contained, balanced refrigeration system, using environmentally safe 404A refrigerant, is conveniently located behind two, one piece louver assemblies. A highly efficient evaporator coil is located out of the food zone. Air circulating fans and forced convection system cooling coil are ceiling mounted. Pressure and temperature aid in creating a displaced curtain of air and unique circulation pattern within the food zone during periods while door is left open.

When the door is closed, interior air-flow pattern design prevents hot pockets and cool spots within the cabinet. Controls shall be up-front, recessed and shall include a digital display of cabinet temperature (with recall capability of temperature set point and actual cabinet temp), master ON/OFF switch with power indicator light, cycle indicator light, and ON DEMAND DEFROST system with indicator light. Adjustable temperature range factory pre-set at 35°F (1.7°C).

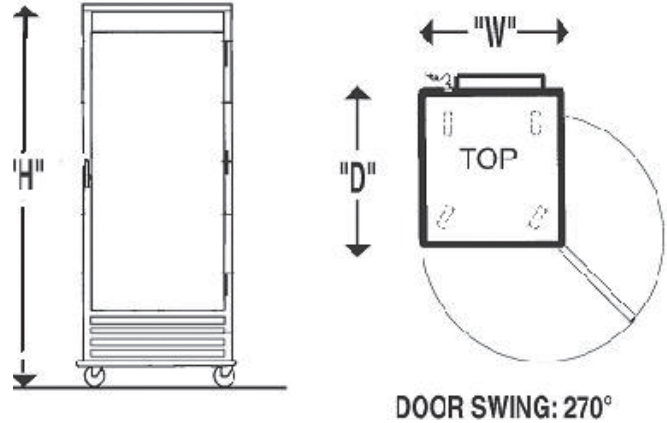

ON DEMAND DEFROST

"On Demand" momentary defrost cycle allows the operator to efficiently force a defrosting of the coils at convenient times to the operation.

ELECTRICAL CHARACTERISTICS

3 wire grounded 8 foot extension power cord and plug, rear mounted for safety. Dedicated circuit. 20 amp NEMA 5-20P, 50/60/1 phase/120 volt.

AIA #

MODEL INFORMATION

MODEL	NUMBER OF TRAY'S	OVERALL SIZE			SHIP WEIGHT	NUMBER OF DOORS
		D	L	H		
AC10	10, 20	37"	34"	80-3/4"	525 lbs.	1

