



## Cantilever Tray & Rack Dispensers

---

With Alluserv you are not just buying a product. You are receiving our team's service commitment to get the most value from your investment in our products. We will provide you with:

- A team of knowledgeable experts with over 100 years of combined experience to help you understand and receive the most from your product throughout its service life
- Detailed instructions and specification on cleaning and application to best maintain your equipment
- A national service network and service manuals for our extensive product offering.

### CANTILEVER TRAY & RACK DISPENSERS

---

#### APPLICATION

The cantilever self-leveling tray and rack dispenser is a convenient way to transport trays to the tray make up area and its ergonomic design reduces the need for bending and stretching to different heights.

#### CONSTRUCTION

The cantilever tray dispensers are stainless steel and allow for trays to be dispensed on a spring-loaded, self leveling mechanism. The carriages are cantilevered to an upright support where 14-gauge stainless steel arms hold the trays. The arms are connected to a bank of springs, located inside the upright supports, which can be hooked and unhooked for proper ergonomic dispensing level. The carriage platform is constructed of 18-gauge stainless steel with 20-gauge upright supports and top. The base is constructed of 18-gauge stainless steel and is fitted with vinyl corner bumpers. The dispenser rests on 5" diameter casters, two with locking brakes. Unit is NSF listed.

Model Numbers:  
**CTD1418, CTD1520, CTD1622,  
CRD2020, DCTD1418,  
DCTD1520, DCTD1622,  
DCRD2020**



# Cantilever Tray & Rack Dispensers

## Standard Features

- Field adjustable by unhooking springs that are connected to the arms. This allows for quick adjustments for the most ergonomic dispensing level.
- Holds tray and rack sizes:
  - 14" x 18" tray
  - 15" x 20" tray
  - 16" x 22" tray
  - 20" x 20" rack
- Fitted with corner bumpers to protect walls as well as your investment.
- Rolls on 5" heavy duty casters, two with locking brakes

## Warranty

- Two years parts and one year labor

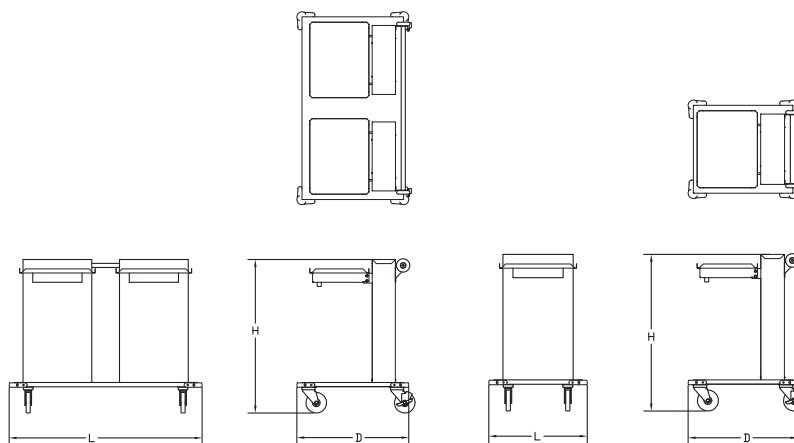

## DIMENSIONS

MODEL	OVERALL SIZE			ACCOMMODATES TRAY SIZE	CASE WEIGHT
	D	L	H		
CTD1418	23-1/2"	26-1/4"	37-13/32"	14" x 18"	112 lbs
CTD1520	23-1/2"	26-1/4"	37-13/32"	15" x 20"	113 lbs
CTD1622	23-1/2"	26-1/4"	37-13/32"	16" x 22"	114 lbs
CRD2020	31-1/2"	23-1/2"	37-13/32"	20" x 20"	114 lbs
DCTD1418	27-1/4"	47"	37-13/32"	14" x 18"	225 lbs
DCTD1520	27-1/4"	47"	37-13/32"	15" x 20"	255 lbs
DCTD1622	32-1/4"	47"	37-13/32"	16" x 22"	226 lbs
DCRD2020	32-1/4"	47"	37-13/32"	12- 10" x 20" 6- 20" x 20"	256 lbs

